

8

7

F

E

D

F3B

F3A

F3H

F4H

F5H

F6H

F6

Corner stringers
are 1/8" square
balsa.

F7

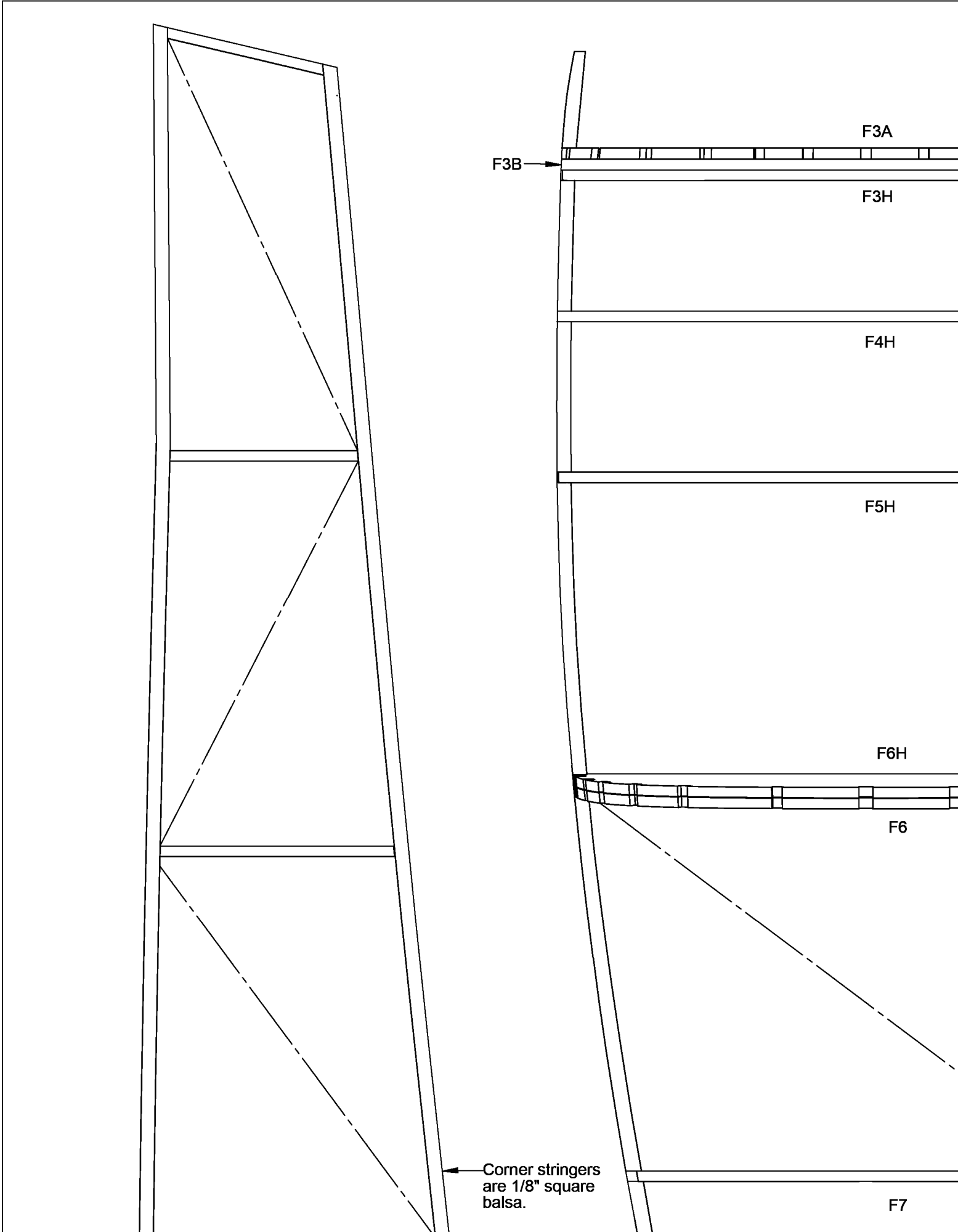

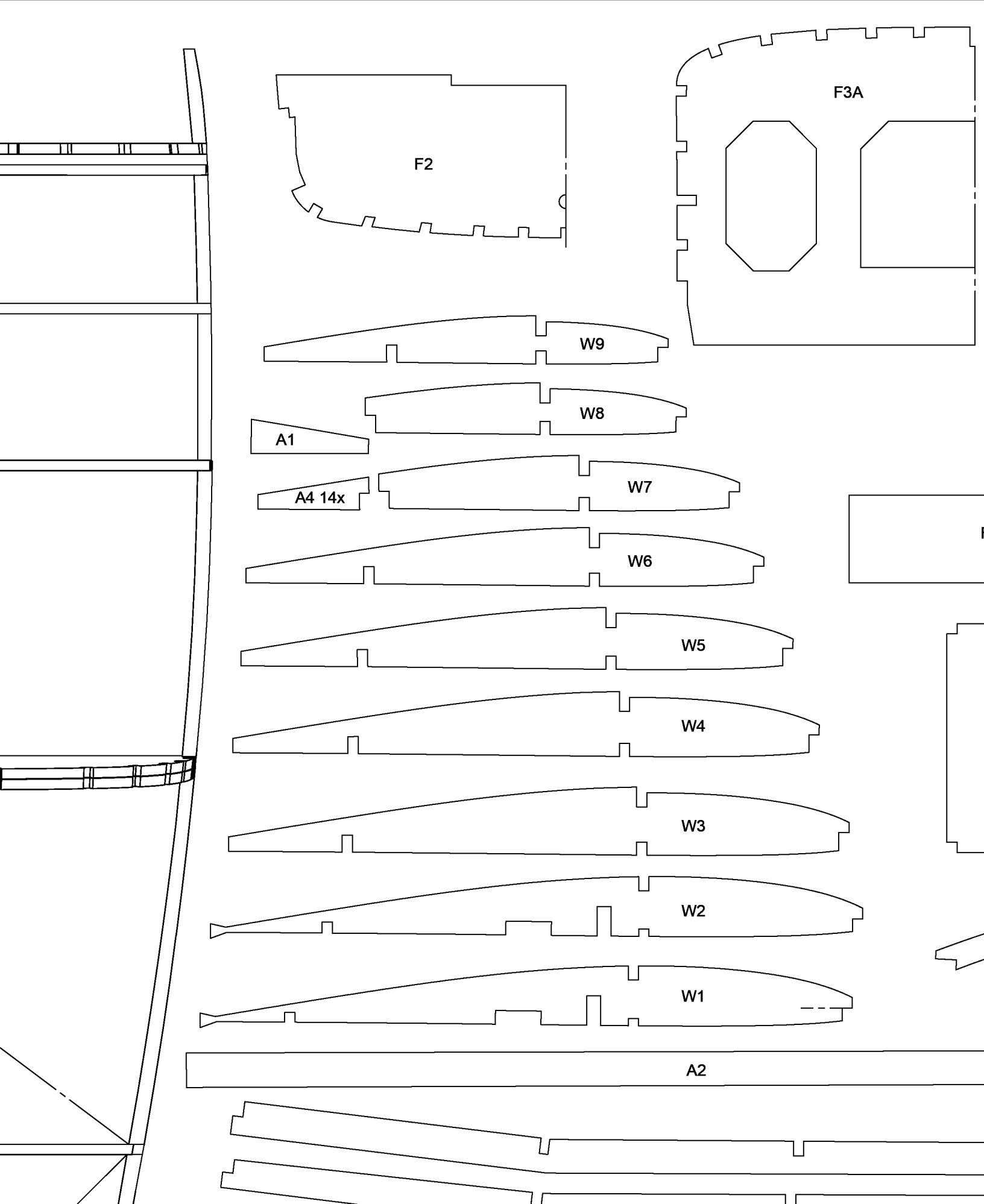

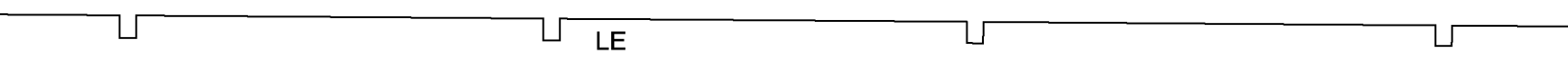
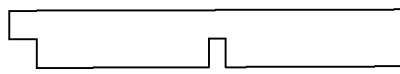
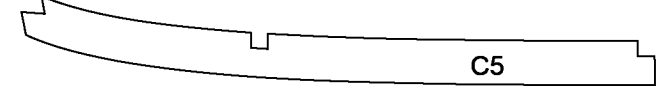
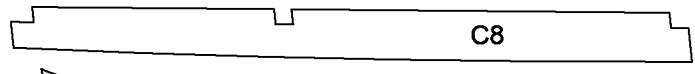
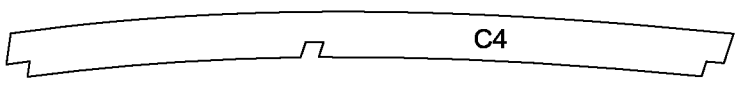
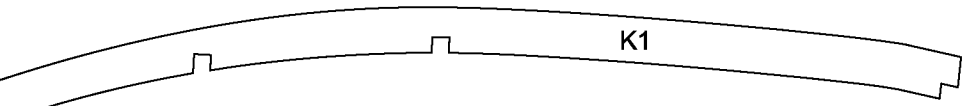
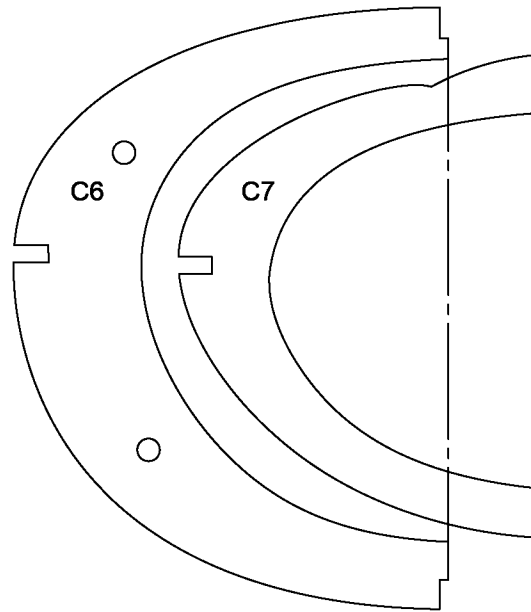
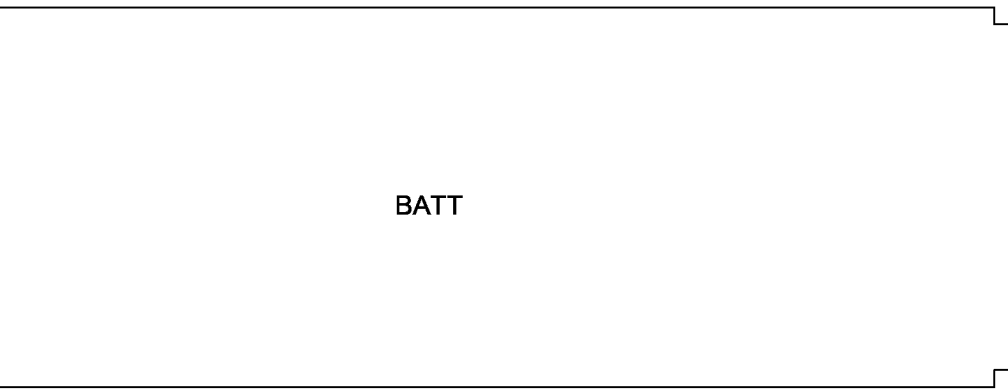
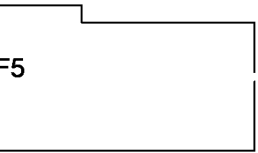
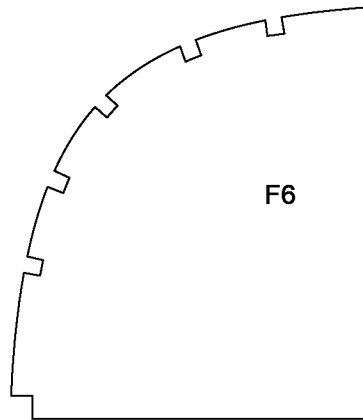
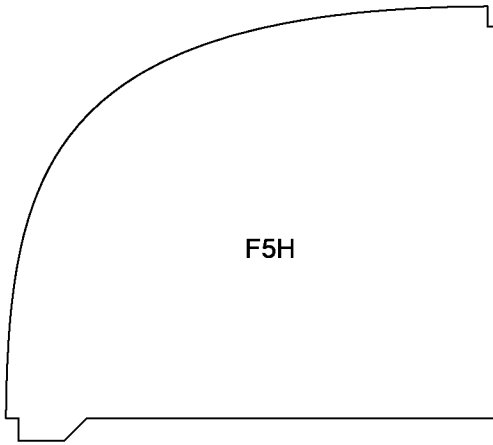
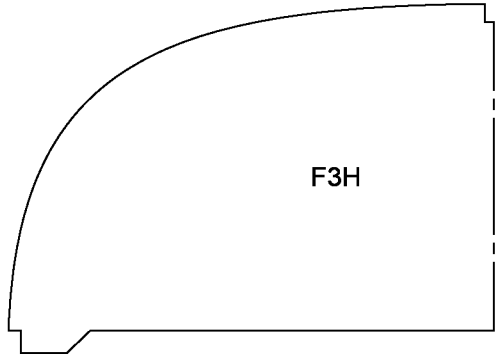
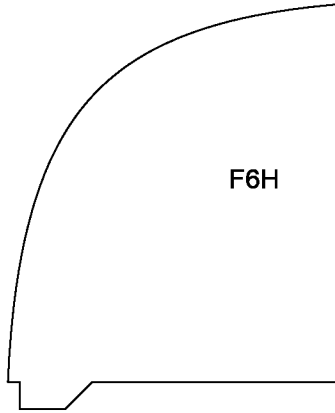
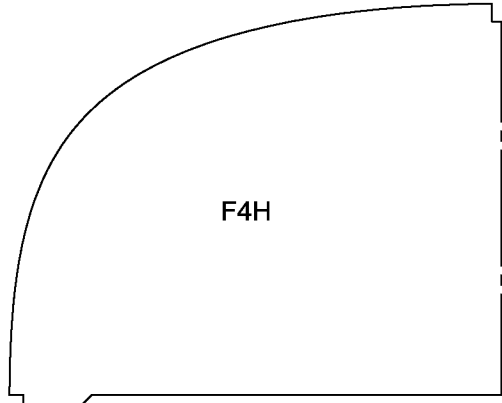
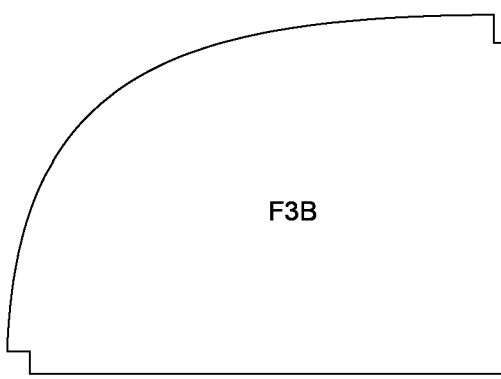

2

1

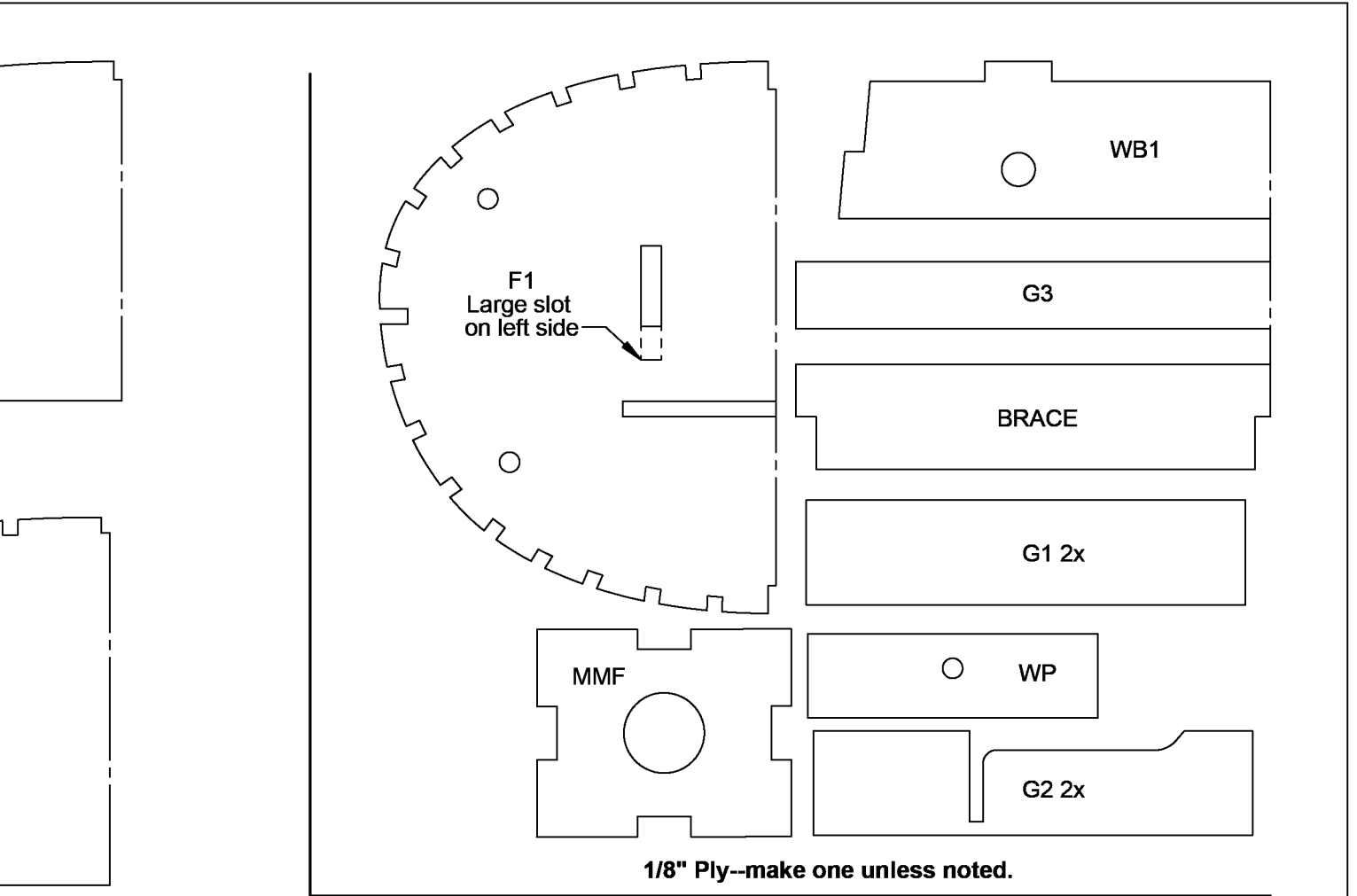

F

E

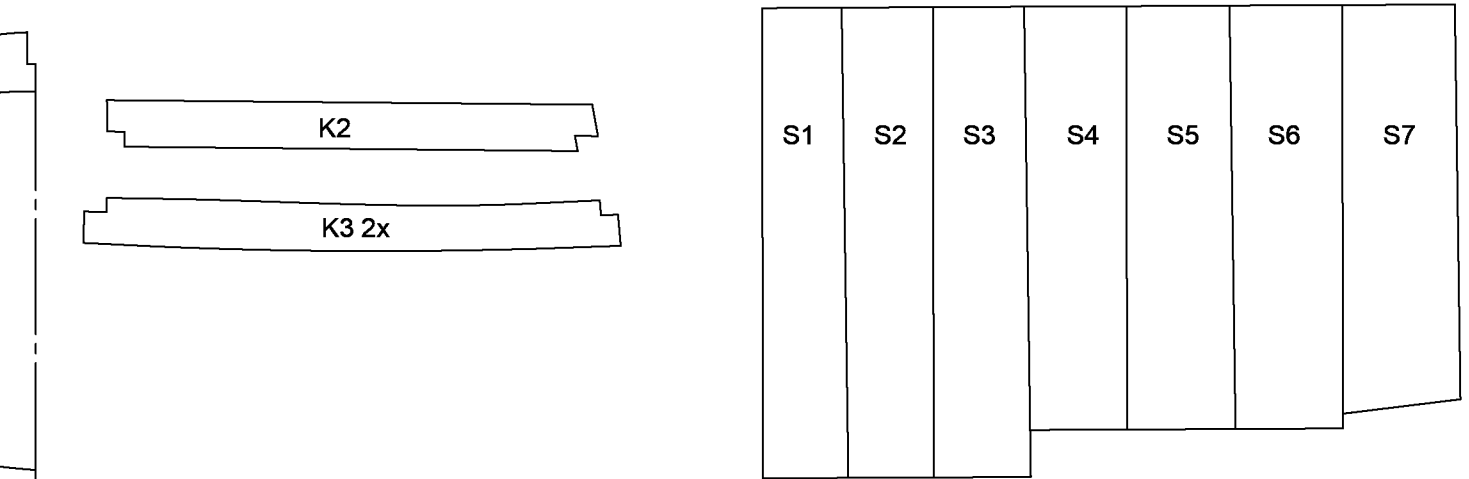

1/16" Balsa--make 2 of all wing parts "W", "S", and "A" unless noted.
 Make one of all others unless noted.

Grain runs horizontal through all parts, all materials.
 Some parts shown left side only to conserve drawing space--include mirror when hand cutting.

D

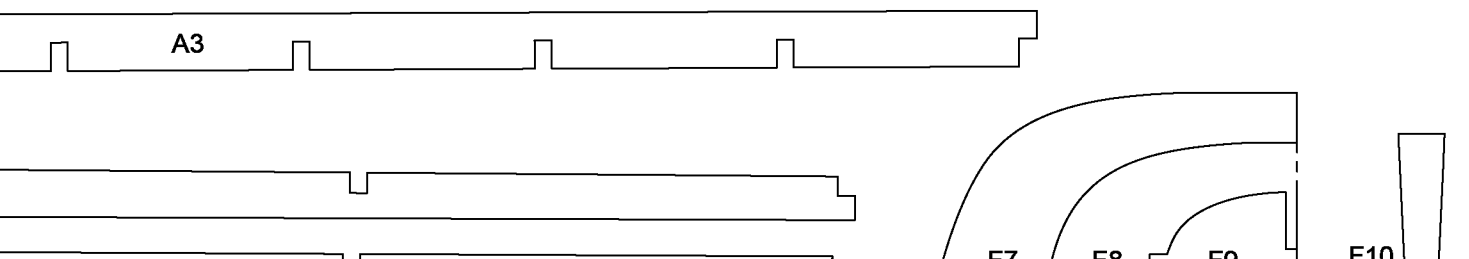

C

B

A

All bracing is 3/32" x 1/8" balsa.

Reinforce Hatch Rail with 1/8" balsa strip

4

3

2

1

1

2

3

4

8

7

WS

F8

F9

F10

Fit F10 flush with bottom of fuselage framework to create a notch here for back corner of Fin to engage

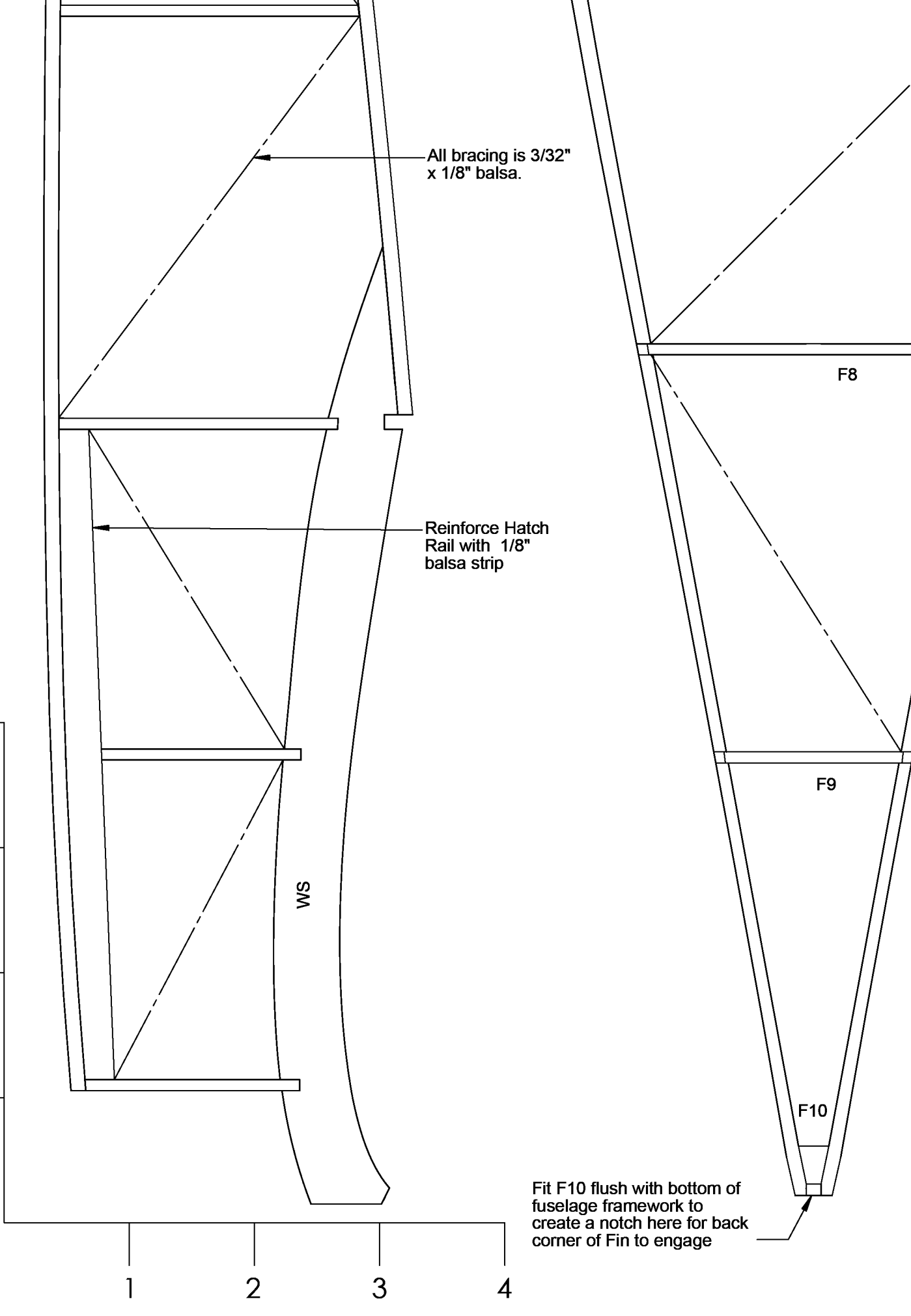



Copying for resale of this drawing without the written approval or consent of IAMA is expressly prohibited.

FUSELAGE NOTES

1. Preassemble the following parts
 1. Wing Pin Hole--reinforce pin hole in F2 with ply part WP.
 2. Wing Boss--epoxy parts WB1 and WB2 together.
 1. Epoxy two 10-32 nuts to the top of WB1 to capture wing screws.
 3. Formers F3A and F3B.
2. Build two identical Side Panels over the plan using the templates to the left.
3. Join the two Side Panels.
 1. Stand the Panels vertically so that the bottom stringer from F10 to F6 is flat against the board,
 2. Epoxy the two Panels together with the Wing Boss assembly and lower Former F5.
 3. Set the upper Panel spacing by gluing in Former F6.
 1. Note that F6 is tipped back to make hatch removal easier.
4. Bring the tail together.
 1. Add the lower crossbraces and upper Formers by working from F7 to F9.
 2. Former F10--attach with its large end flush with the bottom of the two Side Panels.
 1. Note: the gap above F10 will form the notch for the back corner of the Fin.
 3. Add a couple of 3/32" square stringers to hold the Rear Formers in place.
5. Build the Canopy Hatch.
 1. Former F3A/F3B--glue to the front of the Side Panels.
 2. Hatch Formers F3H thru F6H into place--don't glue to Side Panels.
 3. Keel K1--glue to Formers F3B and all H Formers.
6. Close the front of the fuselage.
 1. F2/WP--glue to the forward ends of the Wing Saddles WS.
 2. Battery Tray BATT--glue to F2, F3, and F5.
 3. Firewall F1--attach with Keels K2, K3, and BATT.
7. Complete the Fuselage framework.
 1. Stringers--fill in the rest of the turtledeck and the area between Firewall and F3 with 3/32" square stringers.
 2. Plank the Canopy Hatch from F3H to F6H with 1/16" balsa while it is still attached to the fuselage assembly.
 1. Once cured, cut Keel K1 between Formers F3 and F3H and lift the Canopy/Hatch off.
 2. The Hatch can be held on dowels and magnets in the corners.

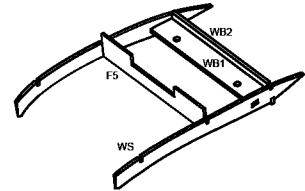

Step 1.2 and 3.2--detail of attachment of Wing Boss to Wing Saddles, other parts omitted.

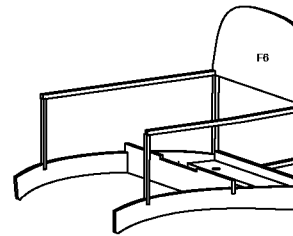

Step 4.2--cross brace

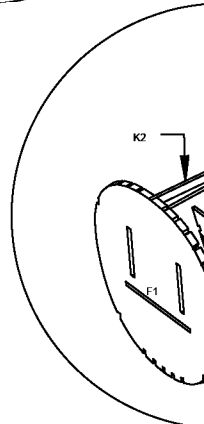
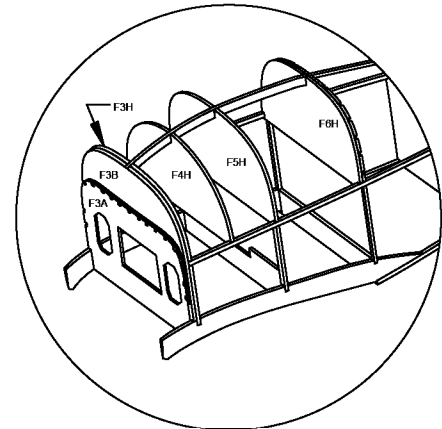

RS

TE

W
out
A

of F5 and Wing
tted for clarity

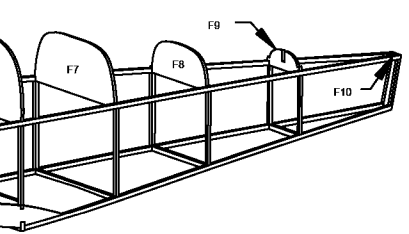

es omitted for clarity

Step 5.3

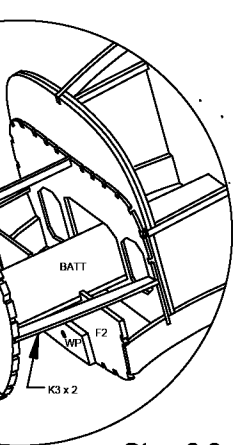

Step 6.3

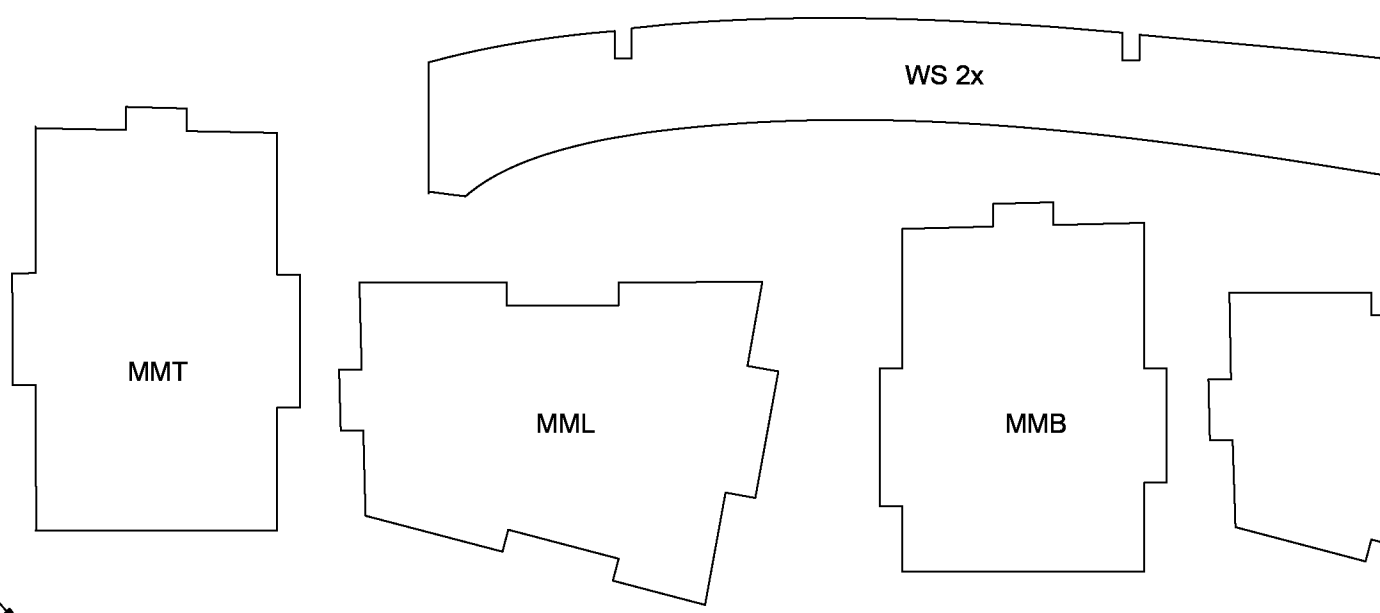

LANDING GEAR TEMPLATES AND NOTES

Use 1/16" music wire and the wire bending templates to form all four landing gear struts.

Nose Wheel: the template shows a fixed Nose Strut that can be lashed to the fuselage.

Alternatively, a steerable nosewheel can be fashioned by extending the the strut as shown by the dashed line. The prototype model used a bearing tube and aluminum tubing that was epoxied to the Firewall behind the Motor Mount arm.

Main Gear: Bend the two Front Main Struts to match the template. Plug the ends of the Main Struts into the pockets in the wing formed by part G1.

Bend the upper vertical portion of each Front Main Strut slightly to provide the amount of back sweep as shown in the side view on Sheet 1 when the struts are in the wing.

The Rear Main Strut is lashed down to the wing along part G3. Adjust the Front Main Struts as needed to get the right geometry, then solder each lower end of the Rear Main Strut to its respective Front Main Strut.

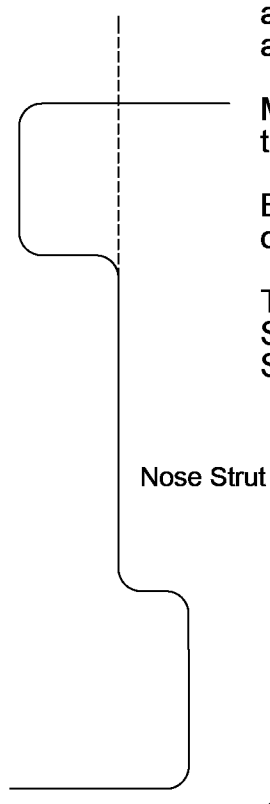

Nose Strut

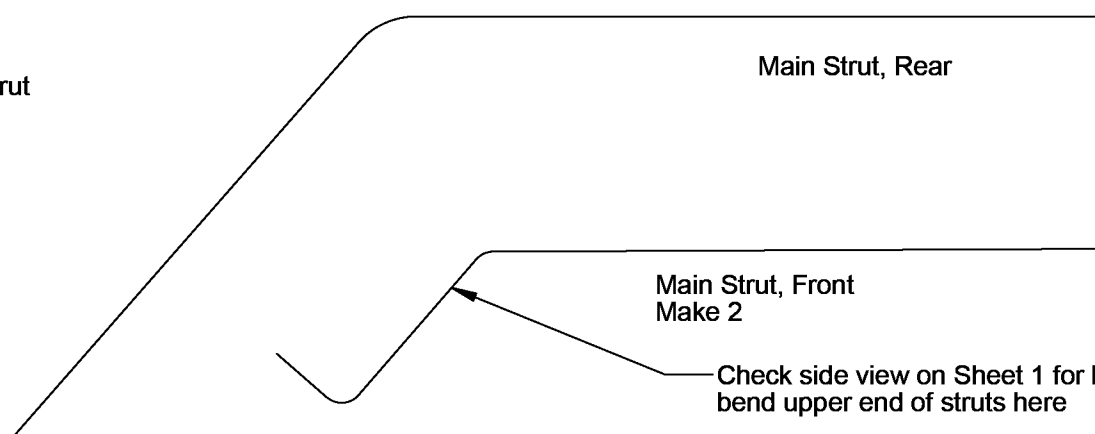

Main Strut, Rear

Main Strut, Front
Make 2

Check side view on Sheet 1 for
bend upper end of struts here

4

3

1/8" Balsa--make one unless noted.

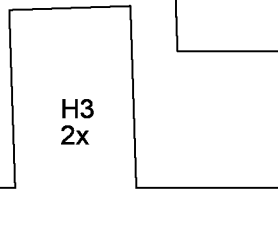
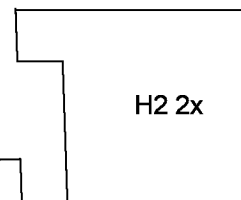
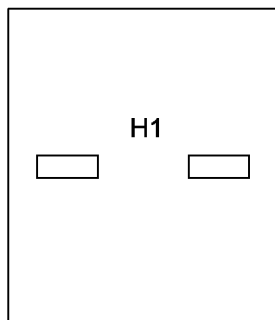
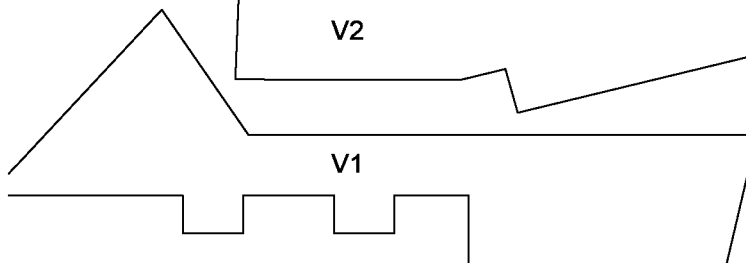
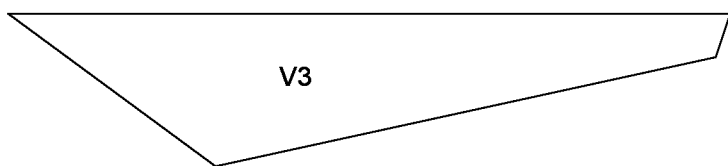
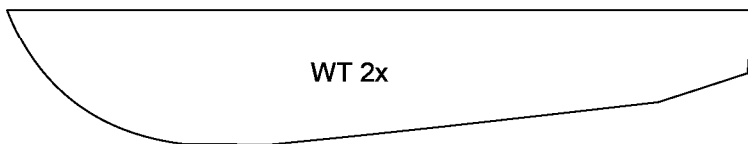
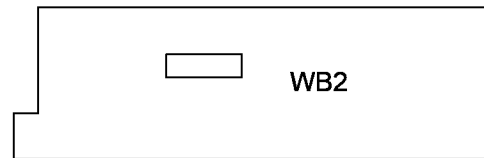
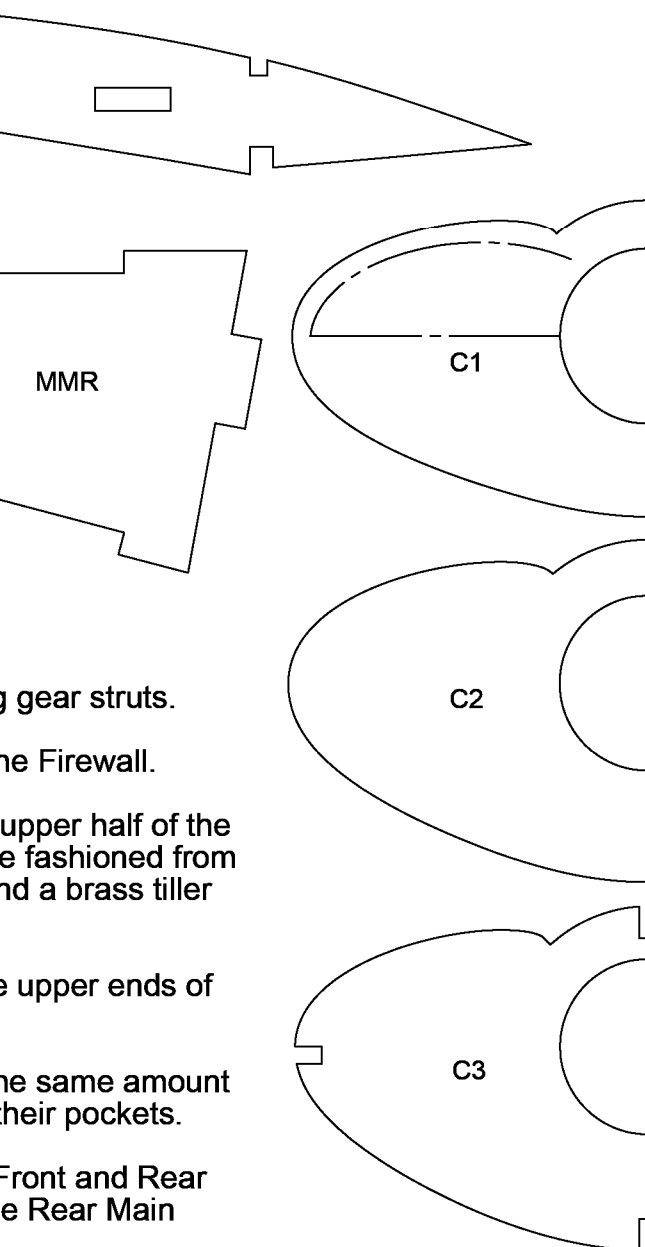

Plans No. 1152

INFIELD ENGINEERINGtm by Paul Kohlmann

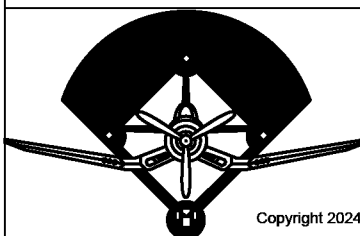

Laser cut kit available!
www.infieldengineering.com

Title
40" Beagle Pup

Size D	Dwg. No. Beagle Pup	Rev A
------------------	-------------------------------	-----------------

Scale: 1:1	Weight: 14-16oz	Sheet 2 of 2
------------	-----------------	--------------

C

B

A